

MOTOR DRIVEN DOSING PUMPS
SPRING SERIES



innovation > technology > future

Plunger piston Metering pumps

PS1 Series

PS1 pumps are plunger piston metering pumps featuring a spring return mechanism in an aluminium housing.

FEATURES

Capacity:	from 1,5 to 304 L/h
Max pressure:	20 BAR
Stroke rate:	58 • 78 • 116 strokes/minute
Piston diameter:	from 6 to 64 mm
Motor:	standard 0,18 and 0,25 Kw (IP 55)
Stroke length:	15 mm



MODEL	PISTON DIAMETER	Strokes/min	FLOW RATE (l/h)	MAX PRESSURE				CONNECTIONS		3phases Motor (kw)
				bar		psi		SS 316	PVC	
				SS 316	PVC	SS 316	PVC			
PS1D006A	6	58	1,5	20	10	290	145	1/4 g f	1/4 g f	0,18
PS1D006B		78	2							
PS1D006C		116	3							
PS1D011A	11	58	5	20	10	290	145	1/4 g f	1/4 g f	0,18
PS1D011B		78	6,5							
PS1D011C		116	10							
PS1D017A	17	58	11	20	10	290	145	3/8 g f	3/8 g f	0,18
PS1D017B		78	15							
PS1D017C		116	22							
PS1D025A	25	58	25	20	10	290	145	3/8 g f	3/8 g f	0,18
PS1D025B		78	32							
PS1D025C		116	50							
PS1D030A	30	58	35	20	10	290	145	3/8 g f	3/8 g f	0,25
PS1D030B		78	45							
PS1D030C		116	70							
PS1D038A	38	58	55	17	10	246,5	145	3/8 g f	3/8 g f	0,25
PS1D038B		78	73							
PS1D038C		116	110							
PS1D048A	48	58	85	10	10	145	145	1/2 g f	1/2 g f	0,25
PS1D048B		78	114							
PS1D048C		116	170							
PS1D054A	54	58	110	8	8	116	116	1/2 g f	1/2 g f	0,25
PS1D054B		78	145							
PS1D054C		116	220							
PS1D064A	64	58	152	6	4	87	58	3/4 g f	3/4 g f	0,25
PS1D064B		78	204							
PS1D064C		116	304							

Piston diameter	SS 316 L			
	A	B	C	T
6	120	210	1/4 g.f.	68
11	120	210	1/4 g.f.	68
17	120	210	3/8 g.f.	68
25	120	215	3/8 g.f.	68
30	120	215	3/8 g.f.	68
38	160	227	3/8 g.f.	88
48	160	227	1/2 g.f.	88
54	173	229	1/2 g.f.	108
64	202	238	3/4 g.f.	108

Piston diameter	PVC			
	A	B	C	T
6	157	216	1/4 g.f.	80
11	157	216	1/4 g.f.	80
17	147	216	3/8 g.f.	80
25	147	225	3/8 g.f.	80
30	147	225	3/8 g.f.	80
38	168	235	3/8 g.f.	100
48	196	240	1/2 g.f.	100
54	216	240	1/2 g.f.	120
64	222	250	3/4 g.f.	120

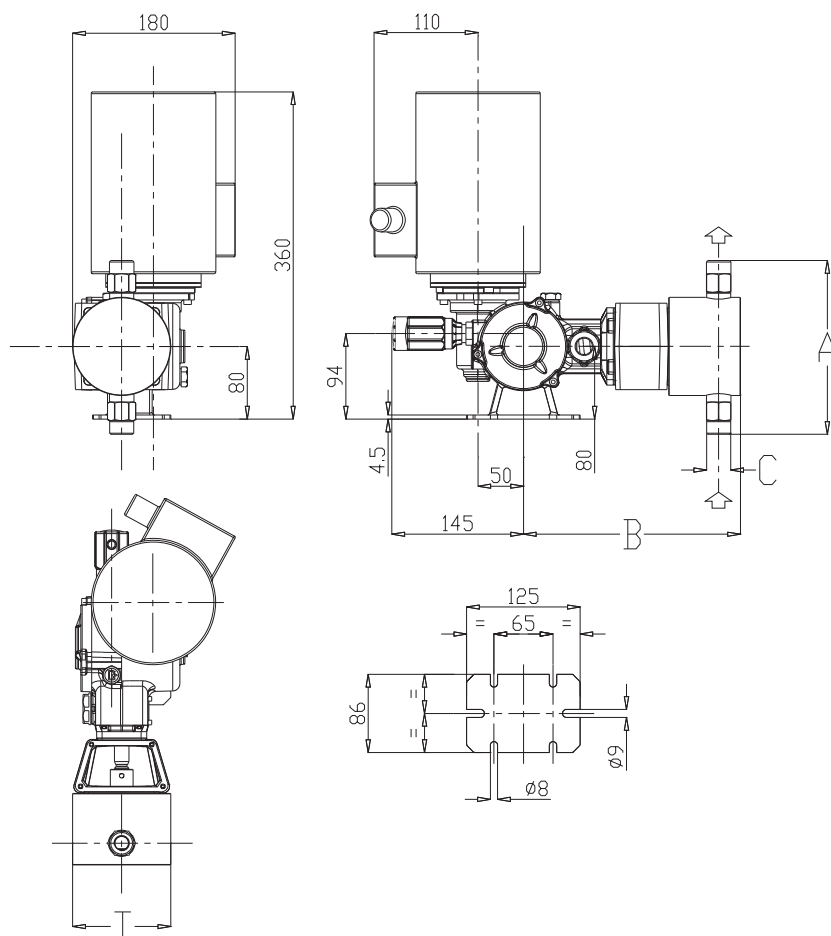

PUMP HEAD MATERIALS

	STANDARD		ON REQUEST	
	21	31	24	34
PUMP HEAD	SS 316	PVC	SS 316	PVC
PISTON	SS 316	Ceramic	Ceramic	Ceramic
PISTON SEAL	FPM	FPM	EPDM	EPDM
VALVES	SS 316	PYREX	SS 316	PYREX
VALVE SEATS	SS 316	PVC	SS 316	PVC

LIQUID END

SS 316 or PVC pump head (standard).

SS 316 OR CERAMIC PISTON

The material in contact with the liquid to be dosed are listed in the "pump head materials" table (special materials may be supplied on request).

MAX DOSAGE TEMPERATURE

- SS 316 pump head: 90° C
- PVC pump head: 40° C

FLOW RATE ADJUSTMENT

Every pump can be equipped with an electric actuator which accepts a 4-20 mA.

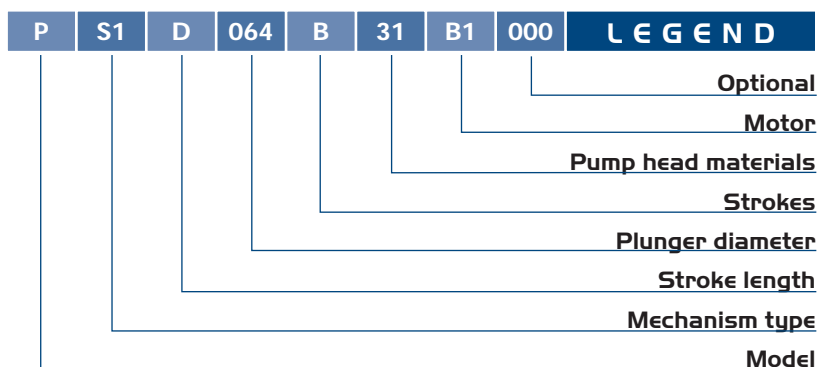

Plunger piston Metering pumps

PS2 Series

PS2 pumps are plunger piston metering pumps featuring a spring return mechanism in an aluminium housing.

FEATURES

Capacity:	from 40 to 1000 L/h
Max pressure:	20 BAR
Stroke rate:	58 • 78 • 116 strokes/minute
Piston diameter:	from 25 to 89 mm
Motor:	standard 0,25 • 0,37 • 0,55 • 0,75 Kw (IP 55)
Stroke length:	25 mm



MODEL	PISTON DIAMETER	Strokes/min	FLOW RATE (l/h)	MAX PRESSURE				CONNECTIONS		3phases Motor (kw)
				bar		psi		SS 316	PVC	
				SS 316	PVC	SS 316	PVC			
PS2E025A	25	58	40	20	10	290	145	3/8 g f	3/8 g f	0,25
PS2E025B		78	53							
PS2E025C		116	80							
PS2E030A	30	58	55	20	10	290	145	3/8 g f	3/8 g f	0,25
PS2E030B		78	75							
PS2E030C		116	112							
PS2E038A	38	58	90	20	10	290	145	3/8 g f	3/8 g f	0,37
PS2E038B		78	120							
PS2E038C		116	180							
PS2E048A	48	58	140	20	10	290	145	1/2 g f	1/2 g f	0,55
PS2E048B		78	190							
PS2E048C		116	284							
PS2E054A	54	58	180	15	10	217,5	145	1/2 g f	1/2 g f	0,55
PS2E054B		78	242							
PS2E054C		116	365							
PS2E064A	64	58	250	10	10	145	145	3/4 g f	3/4 g f	0,75
PS2E064B		78	335							
PS2E064C		116	505							
PS2E076A	76	58	365	7	7	101,5	101,5	1 g f	1 g f	0,75
PS2E076B		78	485							
PS2E076C		116	730							
PS2E089A	89	58	495	5	5	72,5	72,5	1 g f	1 g f	0,75
PS2E089B		78	660							
PS2E089C		116	1000							

Piston diameter	SS 316 L			
	A	B	C	T
25	120	258	3/8 g.f.	68
30	120	258	3/8 g.f.	68
38	160	268	1/2 g.f.	88
48	160	268	1/2 g.f.	88
54	173	268	1/2 g.f.	108
64	202	273	3/4 g.f.	108
76	238	288	1" g.f.	138
89	252	288	1" g.f.	150

Piston diameter	PVC			
	A	B	C	T
25	147	258	3/8 g.f.	80
30	147	258	3/8 g.f.	80
38	168	268	3/8 g.f.	100
48	196	268	1/2 g.f.	100
54	216	268	1/2 g.f.	120
64	222	273	3/4 g.f.	120
76	244	288	1" g.f.	148
89	256	288	1" g.f.	160

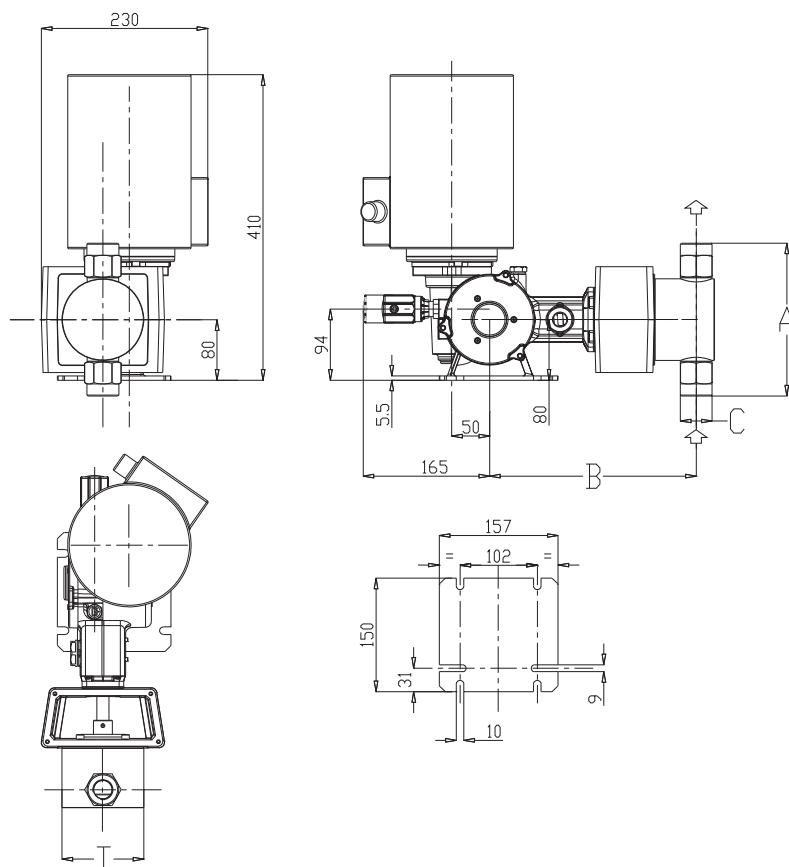

PUMP HEAD MATERIALS

	STANDARD		ON REQUEST	
	21	31	24	34
PUMP HEAD	SS 316	PVC	SS 316	PVC
PISTON	SS 316	Ceramic	Ceramic	Ceramic
PISTON SEAL	FPM	FPM	EPDM	EPDM
VALVES	SS 316	PYREX	SS 316	PYREX
VALVE SEATS	SS 316	PVC	SS 316	PVC

LIQUID END

SS 316 or PVC pump head (standard).

SS 316 OR CERAMIC PISTON

The material in contact with the liquid to be dosed are listed in the "pump head materials" table (special materials may be supplied on request).

MAX DOSAGE TEMPERATURE

- SS 316 pump head: 90° C
- PVC pump head: 40° C

FLOW RATE ADJUSTMENT

Every pump can be equipped with an electric actuator which accepts a 4-20 mA.

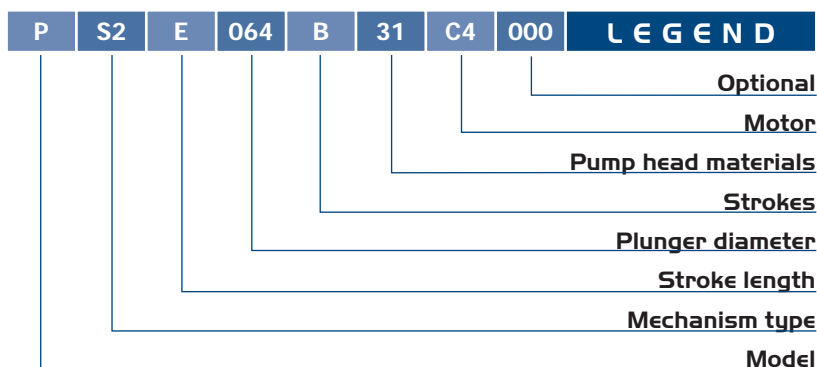

Mechanical Diaphragm Metering Pumps

MS1 Series

MS1 pumps are mechanical diaphragm metering pumps featuring a spring return mechanism in an aluminium housing.

FEATURES

Capacity:	from 5,5 to 460 L/h
Max pressure:	10 BAR
Stroke rate:	58 • 78 • 116 strokes/minute
Diaphragm diameter:	from 65 to 165 mm
Motor:	standard 0,18 • 0,25 • 0,37 Kw (IP 55)
Stroke length:	2 mm • 4 mm • 6 mm



MODEL	DIAPHRAGM DIAMETER	STROKE LENGTH (mm)	STROKES/min	FLOW RATE (l/h)	MAX PRESSURE				CONNECTIONS		3phases Motor (kw)
					bar		psi		SS 316	PP	
					SS 316	PP	SS 316	PP			
MS1A065A	64	2	58	5,5	10	10	145	145	1/4 g f	1/4 g f	0,18
MS1A065B			78	8							
MS1A065C			116	11							
MS1A094A	94	2	58	20	10	10	145	145	3/8 g f	3/8 g f	0,25
MS1A094B			78	26							
MS1A094C			116	40							
MS1B108A	108	4	58	60	10	10	145	145	3/8 g f	3/8 g f	0,37
MS1B108B			78	80							
MS1B108C			116	120							
MS1C138A	138	6	58	155	7	7	101,5	101,5	3/4 g f	3/4 g f	0,37
MS1C138B			78	220							
MS1C138C			116	310					1" g f	1" g f	
MS1C165A	165	6	58	230	5	5	72,5	72,5	1" g f	1" g f	0,37
MS1C165B			78	330							
MS1C165C			116	460							

Diaphragm diameter	PP			
	A	B	C	T
64	208	149	1/4" g.f.	98
94	236	144	3/8" g.f.	117
108	248	144	3/8" g.f.	131
138	347	158	3/4 g.f.	160
			1" g.f.	
165	377	160	1" g.f.	193

Diaphragm diameter	SS 316 L			
	A	B	C	T
64	150	144	1/4" g.f.	98
94	172	146	3/8" g.f.	120
108	212	146	3/8" g.f.	140
138	258	157	3/4 g.f.	170
			1" g.f.	
165	296	157	1" g.f.	190

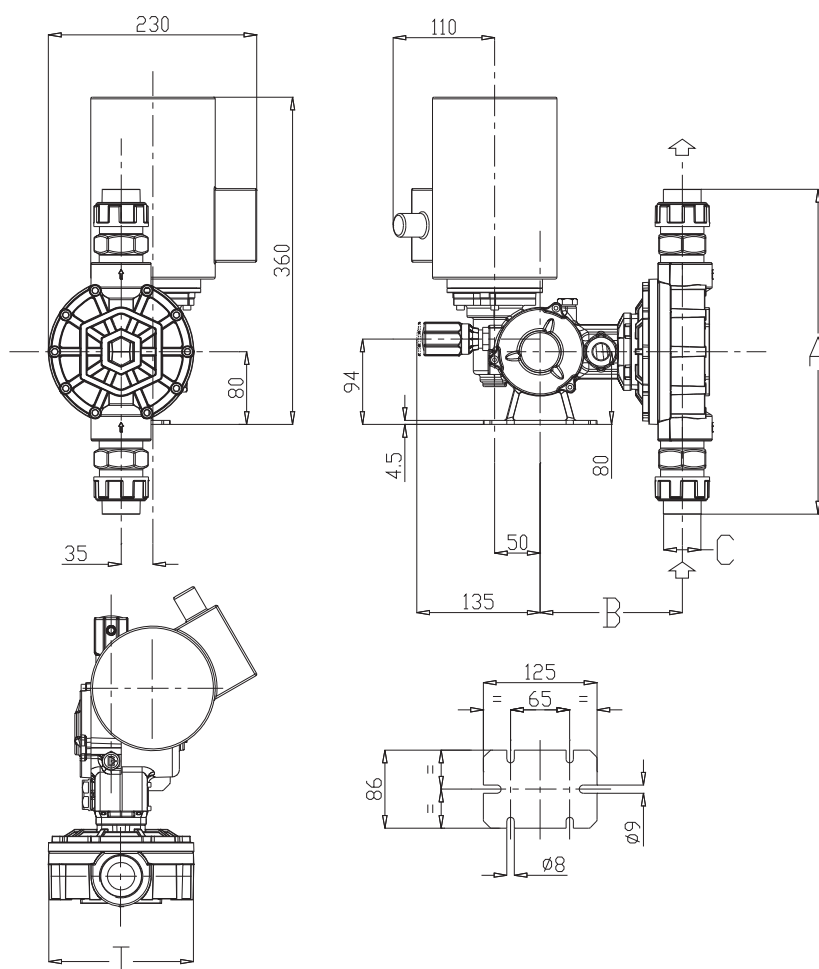

PUMP HEAD MATERIALS

	STANDARD		ON REQUEST	
	21	51	31	41
PUMP HEAD	SS 316	PP	PVC	PVDF
DIAPHRAGM	PTFE	PTFE	PTFE	PTFE
VALVES	SS 316	PYREX	PYREX	Ceramic
VALVE SEATS	SS 316	PVC	PVC	PVDF

LIQUID END

SS 316 or PP liquid end (standard).

PTFE DIAPHRAGM

The material in contact with the liquid to be dosed are listed in the "pump head materials" table (special materials may be supplied on request).

MAX DOSAGE TEMPERATURE

- SS 316 pump head: 40° C
- PP pump head: 40° C

FLOW RATE ADJUSTMENT

Every pump can be equipped with an electric actuator which accepts a 4-20 mA.

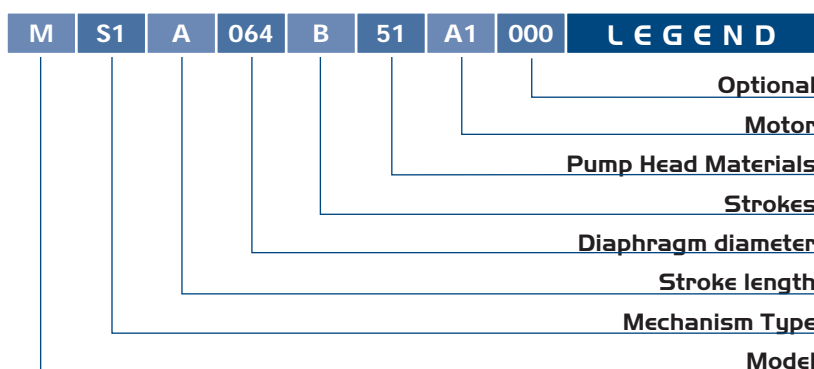

Mechanical Diaphragm Metering Pumps

MSO Series

MSO pumps are mechanical diaphragm metering pumps featuring a spring return mechanism in a plastic housing.

FEATURES

Capacity:	from 17 to 47 l/h
Max pressure:	5 bar
Stroke rate:	41 • 58 • 82 • 116 strokes/minute
Diaphragm diameter:	50 mm
Motor:	standard 0,09 kw (IP55)
Stroke length:	2 mm



MODEL	DIAPHRAGM DIAMETER	STROKES/min	FLOW RATE (l/h)	MAX PRESSURE		CONNECTIONS		3phases Motor (kw)
				bar	psi	SS 316	PP	
MSOF050E	50	41	15	5	72,5	1/2 g m	3/4 g m 1/2 g m	0,09
MSOF050A		58	20					
MSOF050F		82	30					
MSOF050C		116	42					

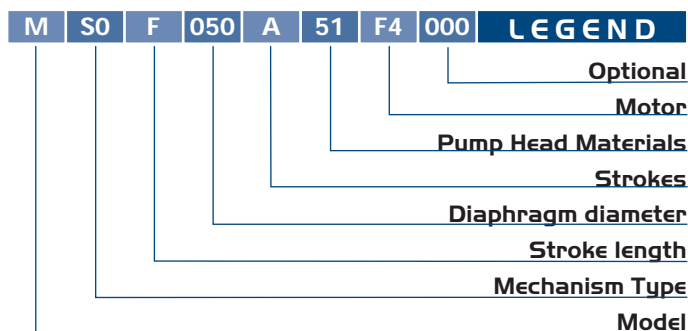
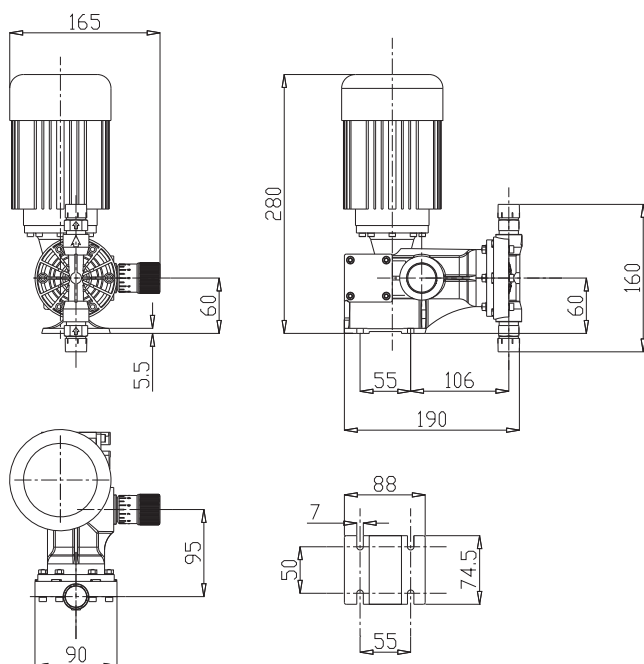

PUMP HEAD MATERIALS

	STANDARD		ON REQUEST
	21	51	31
PUMP HEAD	SS 316	PP	PVC
DIAPHRAGM	PTFE	PTFE	PTFE
VALVES	SS 316	PYREX	PYREX
VALVE SEATS	SS 316	PVC	PVC

ACCESSORIES

Adjustable safety valves (SS316/PTFE)



MODEL	Flow rate l/h	Pressure (bar)		Connections BSP	CODE
		min	max		
VS1S	250	0	19	1/2" F	VS1S250019
		20	45		VS1S250045
		46	150		VS1S250150
VS2S	650	0	13	3/4" F	VS2S650013
		14	30		VS2S650030
		31	100		VS2S650100

Adjustable safety valves



MODEL (material)	Flow rate l/h	Pressure (bar)		Connections BSP	CODE
		min	max		
PRM-S (SS316)	300	0	5	3/8" F	PRM1S03005
	800			3/4" F	PRM2S08005
	1500			1" F	PRM3S15005
PRM-P (PVC)	300	0	5	3/8" F	PRM1P03005
	800			3/4" F	PRM2P08005
	1500			1" F	PRM3P15005

"Y" Suction filters



MODEL (material)	Connections BSP	CODE
FYP PVC	3/8" F	FYP3240200
	1/2" F	FYP3230040
	3/4" F	FYP3230060
	1" F	FYP3230080
FYS (SS316)	3/8" F	FYS3240098
	1/2" F	FYS3240100
	3/4" F	FYS3240110
	1" F	FYS3240120

ACCESSORIES

Backpressure valves (SS316)



MODEL	Flow rate l/h	Pressure (bar)	Connections BSP	CODE
VZX-S-02	50	2	1/4" M	VZX1S00502
	100		1/4" F	VZX3S01002
	200		3/8" F	VZX4S02002
	420		1/2" F	VZX5S04202
	800		3/4" F	VZX6S08002
	1650		1" F	VZX7S16502

Adjustable Backpressure valves



MODEL (material)	Flow rate l/h	Pressure (bar)		Connections BSP	CODE
		min	max		
VSM-S (SS316)	300	0	5	3/8" F	VSM1S03005
	800			3/4" F	VSM2S08005
	1500			1" F	VSM3S15005
VSM-P (PVC)	300	0	5	3/8" F	VSM1P03005
	800			3/4" F	VSM2P08005
	1500			1" F	VSM3P15005

Pulsation bag HTR series



Capacity (L)	Pressure (bar)	Material		Connections BSP	CODE
		Body	Diaphragm		
0,1	230	SS316	NBR	3/8" BSP F	HTRS010N23
0,35				1/2" BSP F	HTRS035N23
0,5					HTRS050N23
0,8					HTRS080N23
1,5					3/4" BSP F
2,3				HTRS230N23	

ACCESSORIES

Pulsation bag HST series



Capacity (L)	Pressure (bar)	Material		Connections BSP	CODE
		Body	Diaphragm		
0,04	10	PVC	FPM	3/8" F	HSTP004V01
0,1					HSTP010V01
0,35				1/2" F	HSTP035V01
0,8					HSTP080V01
1,5				3/4" F	HSTP150V01
2,3					HSTP130V01

Fitting-Testing unit AR series



Pressure (bar)	CODE
6	AR10PM0006
12	AR11PM0012
40	AR01PM0040
60	AR02PM0060
100	AR03PM0100
160	AR04PM0160
250	AR05PM0250

POLYCENDOS

automatic systems for the preparation of polyelectrolyte

The demand for the automatic and continuous preparation of polyelectrolytes, needed in water treatment applications, is brilliantly solved by POLYCENDOS, complete and autonomous systems for the dilution, dispersion, ageing, storage and dosing.

The standard models are in stainless steel and include seven versions from 550 l/h to 8000 l/h; further executions are available upon request.

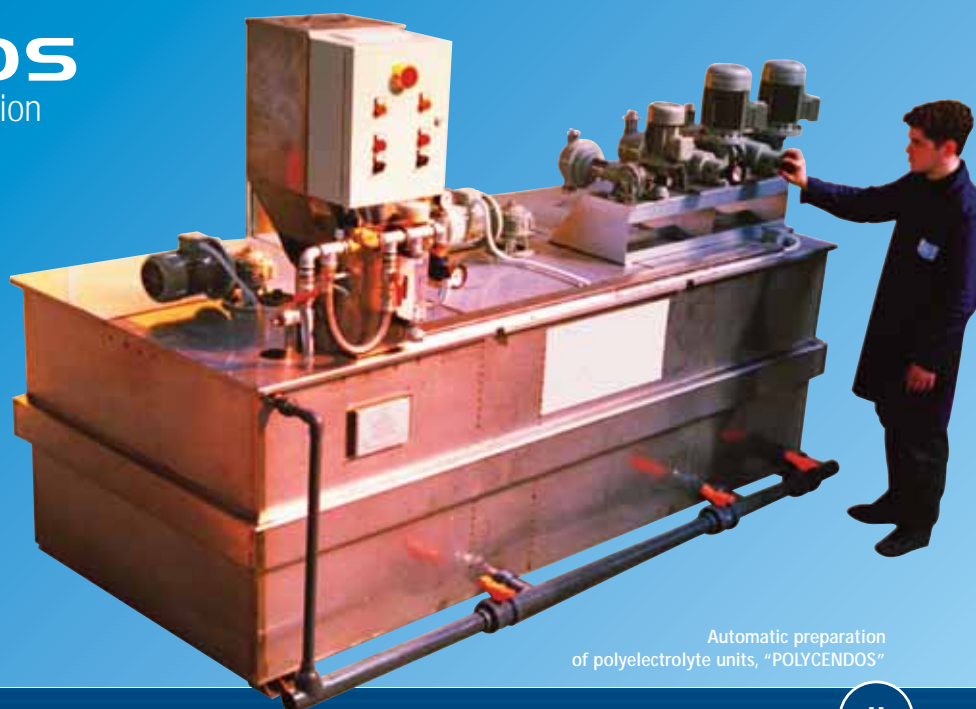

Automatic preparation of polyelectrolyte units, "POLYCENDOS"

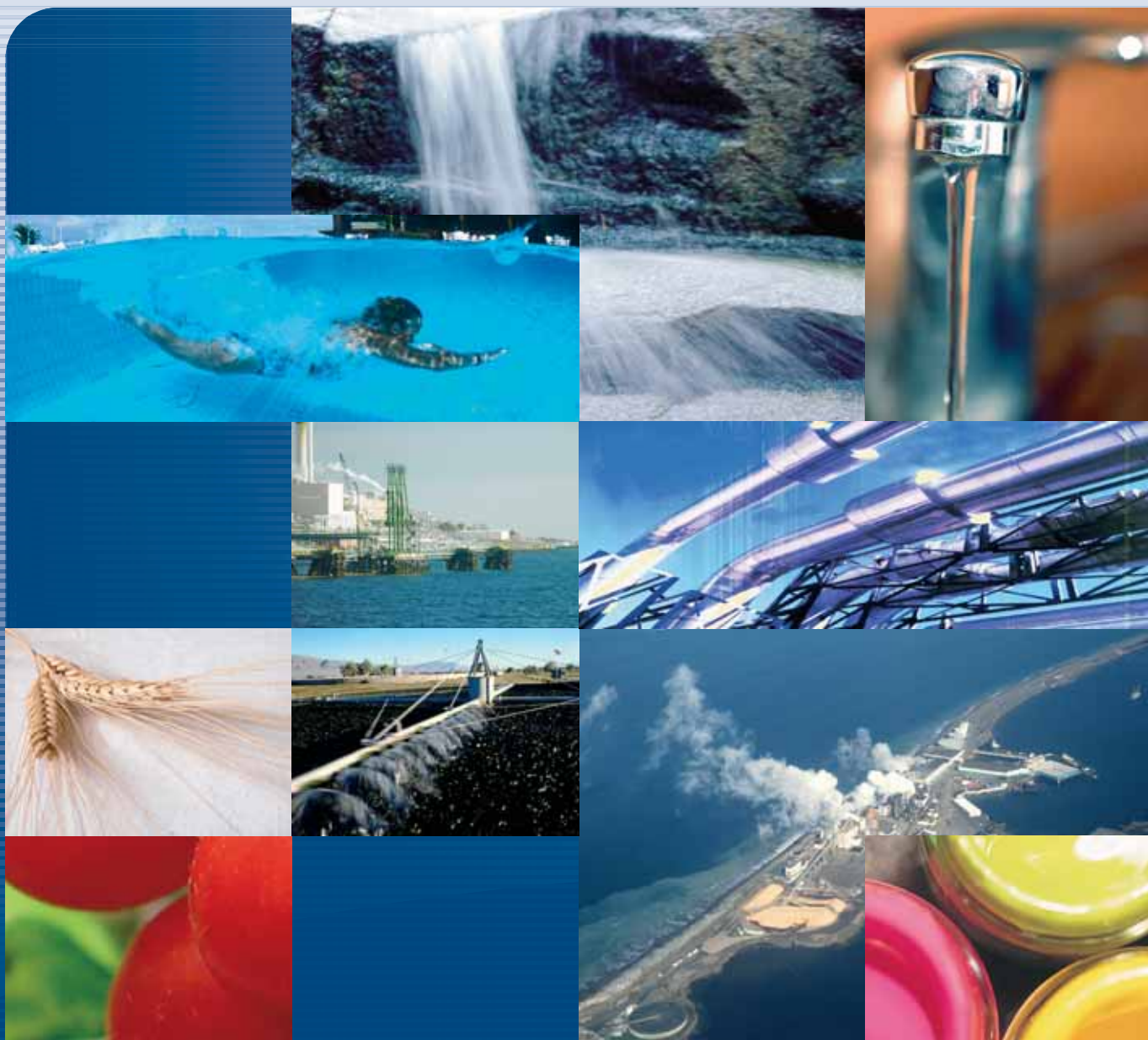

seko

SEKO Asia Pacific **SINGAPORE** • SEKO China **CHINA** • SEKO do Brasil **BRAZIL** • SEKO Dosing Systems **USA** • SEKO Deutschland **GERMANY** • SEKO France **FRANCE** • SEKO Iberica **SPAIN** • SEKO Italia **ITALY** • OOO SEKO **RUSSIA** • SEKO Northern Europe **DENMARK** • SEKO SIETA **ROMANIA** • SEKO Southern Africa **SOUTH AFRICA** • SEKO UK **UNITED KINGDOM**

www.seko.com

BRO SPRUK 081
The technical data may be altered without prior warning. The drawings and images are for illustrative purposes only.